

ADVANCED PACKAGING
TECHNOLOGIES

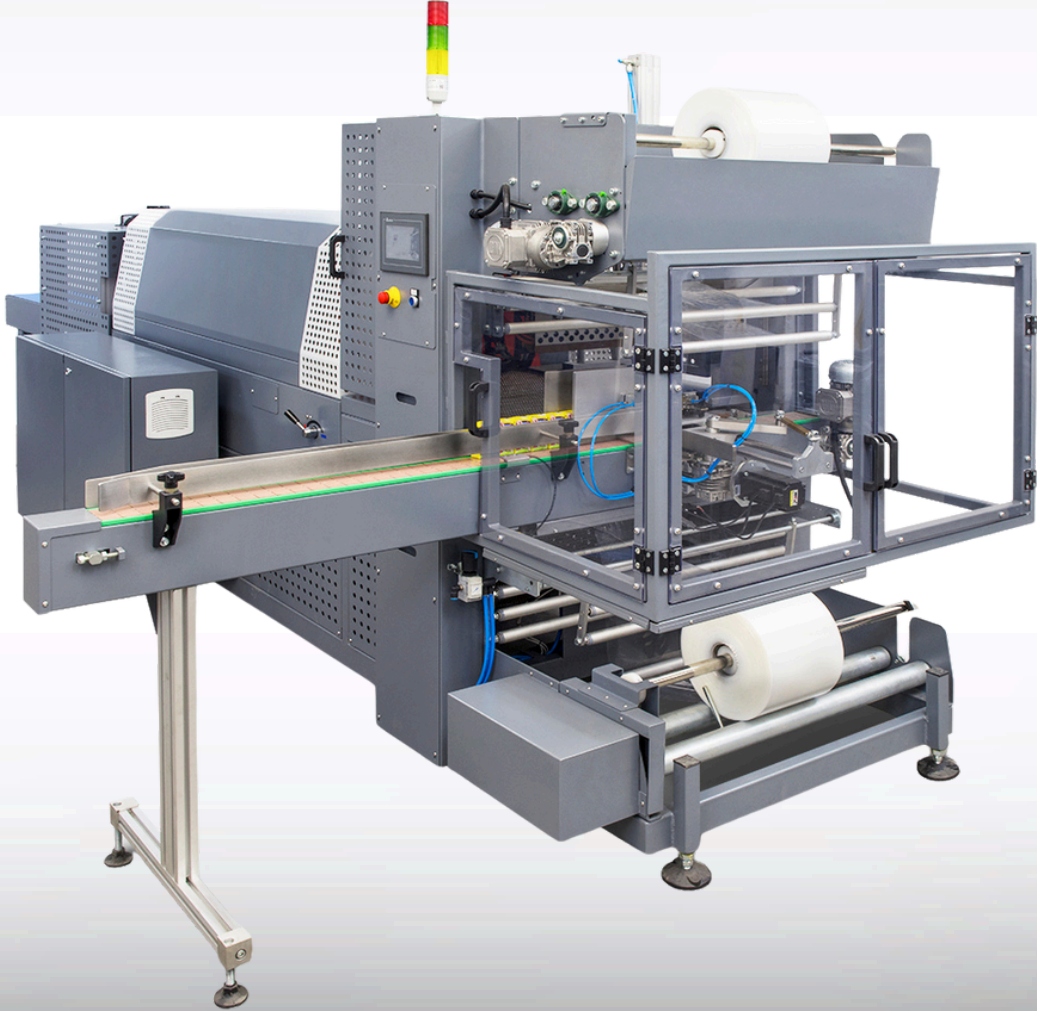

PE-C SERIES

SIDE FEED AUTO-SLEEVE WRAPPER

GROW YOUR BUSINESS

www.packpark.com.tr



PE-C SERIES

SIDE FEED AUTOMATIC SLEEVE WRAPPER

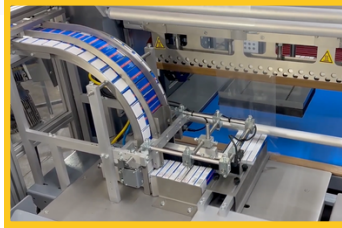
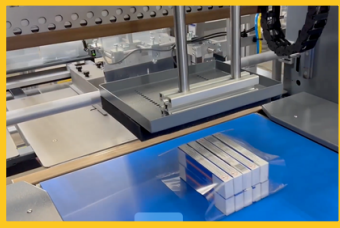
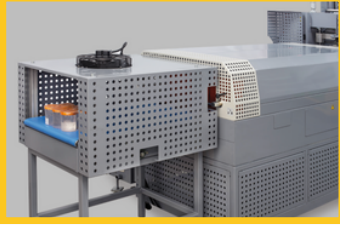

Advantages:

- 90° Infeed belt for automatic infeed
- Multi-product grouping capability with 90° feed belt
- Easy to use, compatible with health and safety standards
- Portable mono-block chassis on caster wheels with brakes
- Recordable and re-callable temperature adjustments

Features:

- Photo eye control for package infeed
- Motorized pusher with side guides for package infeed
- User-friendly colorful touch screen operator panel
- Ability to read instant or total realized capacity by counter
- Automatic film feeding with motor driven roll film chamber

Sealing:

- Perfect sealing with double linear bearing cutting jaw
- Lower jaw profile with Teflon tape coating on silicone
- Teflon coated hot cutting thick welding upper jaw
- Welding blades suitable for different packaging materials
- Photocell for under-jaw product detection and protection

Flexibility:

- Easy adjustment for different capacities and product sizes
- Various language options and adaptable touch keyboard
- All parameters can be entered via the color touch screen
- Memory Receipt property for prompt adjustments
- Blade structure is suitable for films of different thicknesses

Optional:

- Printed film control system
- Automatic top-bottom easy film drive systems
- Spare reel chamber and film splicing (manual) system
- Ability to control external belts from the operator panel
- Product balancing or pressing with top press piston

Quality:

- ISO 9001 quality standard with the relevant norms
- CE marking
- One year warranty on non-wearable parts
- Manufacturer's guarantee for spare part & after sales
- 1 set of wear parts is provided along with the machine



www.packpark.com.tr

**INDUSTRIAL
PACKAGING**

PE-C SERIES

SIDE FEED AUTOMATIC SLEEVE WRAPPER

SPECIFICATIONS

Sealer Opening:
Max. Speed:
Max. Cycle:
Max. Roll Diameter:
Working Height (D):
Comp. Air Supply:
Comp. Air Consumption:
Film Types:
Color:

400mm
10 - 15 mt/min (adjustable)
8 - 10 cycle/min
Ø 350mm (adjustable)
960mm
6 bar
12 litre / cycle
PE 30-80 micron
Mixed grey + RAL7015 + RAL7010

TECHNICAL DATA

Max. Packaging Sizes (WxLxH):
Cross Sealer Length:
Conveyor Belt Width:
Max. Film Width:
Installed Power (50-60 Hz):
Consumption (Maximum/Average):
Dimensions (AxBxC):

PE 60 C

600 x 550 x 400mm
680mm
600mm
650mm
400V, 44 Ampere, 3 Phase
13,2kW / 7,5kW
3350 x 255 x 1350mm

PE 80 C

800 x 550 x 400mm
840mm
800mm
850mm
400V, 46 Ampere, 3 Phase
17,2kW / 8,5kW
3350 x 255 x 1350mm

* Optional: Top Pressure Cylinder, 2,4 L/Cycle

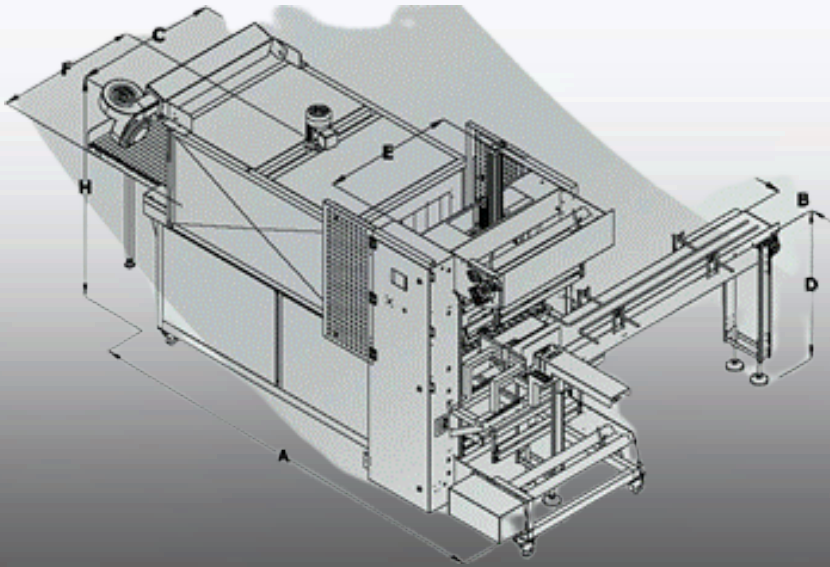

www.packpark.com.tr

**INDUSTRIAL
PACKAGING**

FOR MORE INNOVATIVE
PACKAGING SOLUTIONS



info@packpark.com.tr



+90 533 690 0555



Park Industrial Packaging Equipments Ltd.
Esentepe, Kelebek Sk. No:2, Marmara Kule A Blok 203, 34870 Kartal/İstanbul - TÜRKİYE
Tel. +90 216 353 5466 Mobile/WhatsApp: +90 533 690 0555
info@packpark.com.tr www.packpark.com.tr

**INDUSTRIAL
PACKAGING**