

ADVANCED PACKAGING
TECHNOLOGIES



20/40
PRO-SERIES

CONTINUOUS SIDE SEALERS

GROW YOUR BUSINESS

www.packpark.com.tr



PRO-SERIES 20/40

CONTINUOUS SIDE SEALERS

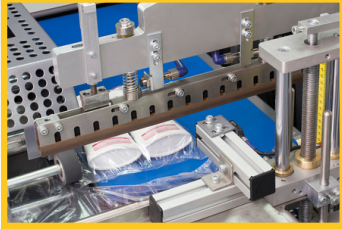

Advantages:

- New 'Pro' design version, compact and more aesthetic
- Unlimited package length with continuous sealing system
- Fast and precise bagging with servo-driven cutting
- Easy to integrate directly into production lines
- Memorable temperature and position adjustments

Features:

- Automatic length detection with encoder and sensor
- User-friendly color touch screen operator panel
- Automatic packaging film drive with tension control
- Automatic trim winder with tension control
- Package feed interval control with sensor and PLC

Sealing:

- Smooth and linear weld line with center weld feature
- Adjustable cutting force and pressure accuracy
- PID controlled temperature settings on the touch panel
- Welding blades suitable for various packaging materials
- Under-seal bar product control and product protection

Flexibility:

- Easy adjustment for different product sizes and capacities
- Various language options and adaptive touchscreen
- Memory Receipt property for prompt adjustments
- Perfect sealing blade design for varying thicknesses

Optional:

- Ability to work without the need for compressed air
- External belt speed control from operator panel
- Sensor and programming for printed film use
- Ability to use single layer flat film with center folding unit

Quality:

- ISO 9001 quality and CE certificates
- Festo Pneumatics, Eaton, Omron, Siemens components
- 1 year warranty, 5 years spare parts supply warranty
- Spare parts stock and manufacturer support after sales



www.packpark.com.tr

**INDUSTRIAL
PACKAGING**

PRO-SERIES 20/40

CONTINUOUS SIDE SEALERS

SPECIFICATIONS

Sealer Opening:
Max. Speed:
Max. Cycle:
Max. Roll Diameter:
Working Height:
Film Types:
Color:

250mm
30mt/min (adjustable)
20-30 packs/min*
Ø 300mm standard (adjustable)
860mm
7-40 µm PO, PP, PE "V" Knife, 40-80 µm PE, OPP "W" Knife
Mixed grey + RAL7010 + RAL7015

TECHNICAL DATA

Max. Packaging Sizes (WxLxH):
Cross Sealer Length:
Conveyor Belt Width:
Max. Film Width:
Installed Power (50-60Hz):
Consumption Max. / Average
Dimensions (AxBxC):
Palletized Size (AxBxC):
Weight (Net / Gross):

PRO 20

150 x Unlimited x 200mm
300mm
200mm
650mm
400V, 6 Ampere, 3 Phase
6kW / 3kW
1310 x 2080 x 1895mm
1200 x 2270 x 1675mm
624 kg / 690 kg

PRO 40

350 x Unlimited x 250mm
530mm
400mm
650mm
400V, 6 Ampere, 3 Phase
6kW / 3kW
1510 x 2080 x 1895mm
1400 x 2270 x 1675mm
780 kg / 860 kg

* Real working speed depends on the product dimensions and the film type.

* Kissing Belt requires air. Air requirement: 6 Bar, Air Consumption: 1liters / cycle

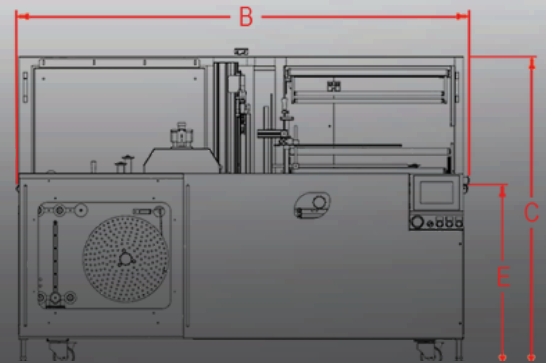
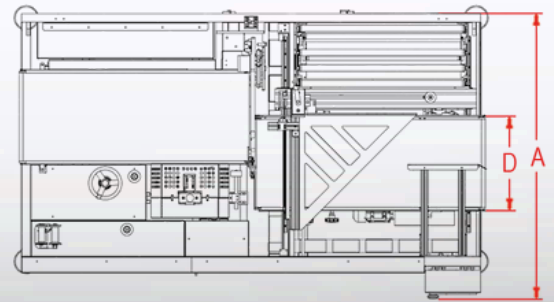
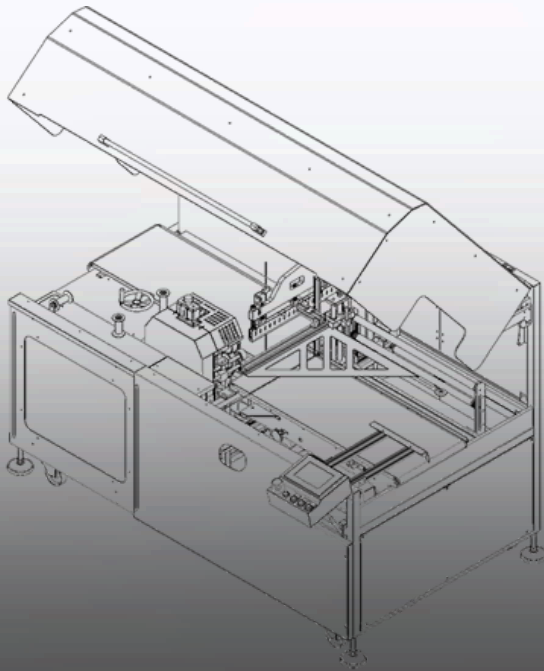

www.packpark.com.tr

**INDUSTRIAL
PACKAGING**

FOR MORE INNOVATIVE
PACKAGING SOLUTIONS



info@packpark.com.tr



+90 533 690 0555



Park Industrial Packaging Equipments Ltd.
Esentepe, Kelebek Sk. No:2, Marmara Kule A Blok 203, 34870 Kartal/İstanbul - TÜRKİYE
Tel. +90 216 3535466 Mobile/WhatsApp: +90 533 690 0555
info@packpark.com.tr www.packpark.com.tr

**INDUSTRIAL
PACKAGING**