

ADVANCED PACKAGING  
TECHNOLOGIES



# MOTION-PRO

HIGH SPEED SHRINK WRAPPING

**GROW YOUR BUSINESS**

[www.packpark.com.tr](http://www.packpark.com.tr)



# MOTION-PRO SERIES

## HIGH SPEED CONTINUOUS SIDE SEALER

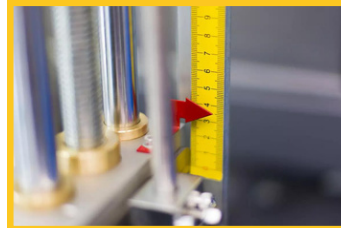
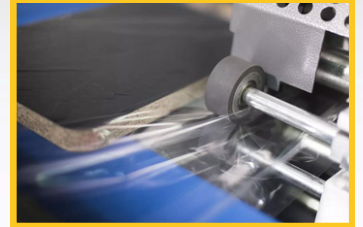

### Advantages:

- Nonstop operation with continuous motion system
- Dual axis servo motor driven cross sealing
- High precision and consistency with cross and side seal
- Packaging with no length limit
- Maximum savings with controlled film consumption
- Compact ergonomic design that takes up little space
- Reduced energy & increased safety

### Features:

- Touch control panel with color screen
- Easy format change for different package sizes
- Ergonomic operator panel with most useful hard buttons
- Safety electric and mechanic measures of CE directives
- Cross and continuous knives with PID controlled heaters
- Photocell controlled package distance positioned feeding
- Automatic length detection option

### Sealing:

- Non stop and tight film sealing operation
- Up to 15% advantage in film consumption
- Film tension releasing on the cross-sealing point
- Height adjustable cross sealer (Optional motorized)
- Adjustable "Central Sealing" for variable package height

### Flexibility:

- Native languages can be applied
- Recipe application with different package dimensions
- Warning messages for potential emergency cases
- Trim winder to control very thin films without breakage
- Real production data with "Navigation Control"

### Optional:

- Double seal feature on cross sealer higher thickness films
- Control of external conveyors through operator panel
- Vertical photocell to detect thin packages
- Printed marker registered film detection & application

### Quality:

- ISO 9001 quality standard with the relevant norms
- CE marking
- One year warranty on non-wearable parts
- Manufacturer's guarantee for spare part & after sales



[www.packpark.com.tr](http://www.packpark.com.tr)

**INDUSTRIAL  
PACKAGING**

# MOTION-PRO SERIES

## HIGH SPEED CONTINUOUS SIDE SEALER

### SPECIFICATIONS

Sealer Opening:  
Max. Speed:  
Max. Cycle:  
Max. Roll Diameter:  
Working Height:  
Film Types:  
Color:

250mm  
30mt/min  
80 packs/min\*  
Ø270mm  
860mm (Optionally Higher +50mm)  
7-40 µm PO, PP "V" Knife 40-60 µm PE, OPP "W" Knife  
Mixed grey + RAL7010 + RAL7015

### TECHNICAL DATA

Max. Package Sizes WxLxH  
Cross Sealer Length:  
Conveyor Belt Width:  
Max. Film Width:  
Installed Power (50-60Hz)  
Consumption Max/Avrg  
Dimensions (AxBxC):  
Palletized Size (AxBxC):  
Weight (Net/Gross):

### BOX-MOTION 20

170 x Unlimited x 250mm  
400mm  
200mm  
700mm  
400V, 3x7 Ampere, 3 Phase  
7kW/5kW  
1190 x 3255 x 1885mm  
1500 x 3450 x 1600mm  
700kg/790kg

### BOX-MOTION 40

370 x Unlimited x 250mm  
540mm  
400mm  
700mm  
400V, 3x7 Ampere, 3 Phase  
7kW/5kW  
1400 x 3255 x 1885mm  
1500 x 3400 x 1600mm  
980kg/1010kg

### BOX-MOTION 60

570 x Unlimited x 250mm  
730mm  
600mm  
1000mm  
400V, 3x7 Ampere, 3 Phase  
7kW/5kW  
1855 x 3755 x 1930mm  
2000 x 3950 x 1650mm  
1090kg/1250kg

\*Real working speed depends on the product dimensions and the film type.  
\*Minimum packaging width for Box-Motion 60 series: 250mm

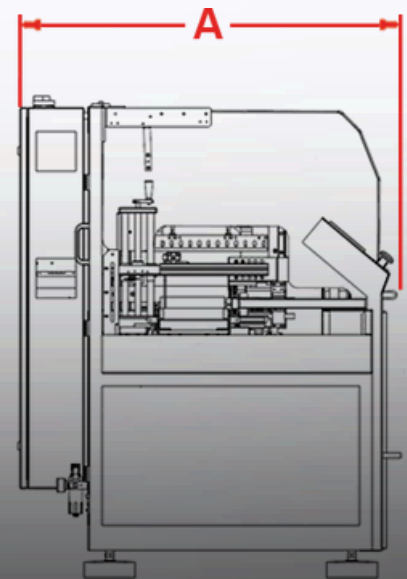
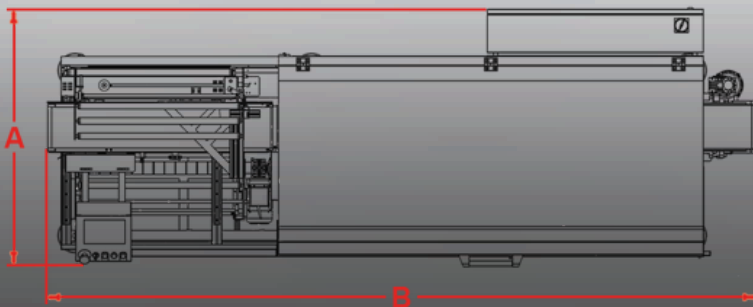
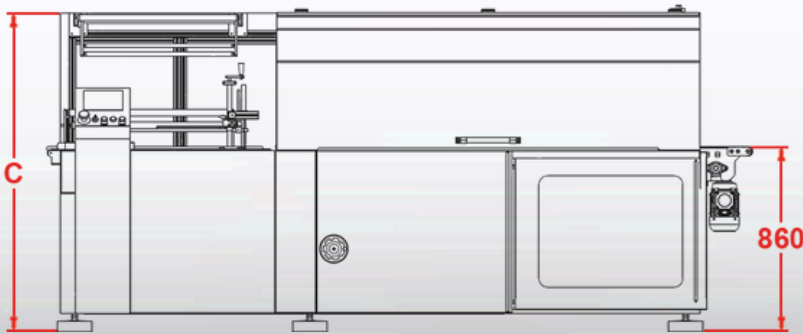

[www.packpark.com.tr](http://www.packpark.com.tr)

**INDUSTRIAL  
PACKAGING**

FOR MORE INNOVATIVE  
PACKAGING SOLUTIONS



 [info@packpark.com.tr](mailto:info@packpark.com.tr)

 +90 533 690 0555



**Park Industrial Packaging Equipments Ltd.**  
Esentepe, Kelebek Sk. No:2, Marmara Kule A Blok 203, 34870 Kartal/İstanbul- TÜRKİYE  
Tel. +90 216 353 5466 Mobile/WhatsApp: +90 533 690 0555  
[info@packpark.com.tr](mailto:info@packpark.com.tr) [www.packpark.com.tr](http://www.packpark.com.tr)

**INDUSTRIAL  
PACKAGING**