

ADVANCED PACKAGING  
TECHNOLOGIES



# HYBRID SERIES

HIGH PRODUCT AUTO SHRINK WRAPPER

**GROW YOUR BUSINESS**

[www.packpark.com.tr](http://www.packpark.com.tr)



# HYBRID SERIES

## HIGH PRODUCT AUTO SHRINK WRAPPER

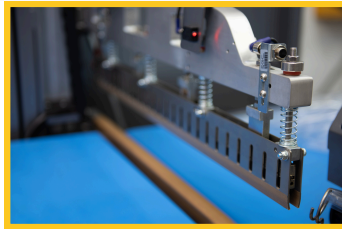
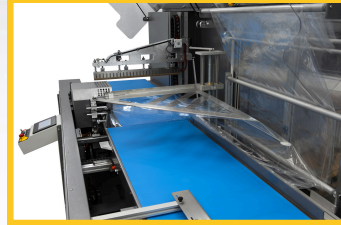

### Advantages:

- New 'Pro' design version, compact and more aesthetic
- Unlimited package length with continuous sealing system
- Fast and precise bagging with servo-driven cutting
- Easy to integrate directly into production lines
- Memorable temperature and position adjustments

### Features:

- Automatic length detection with encoder and sensor
- User-friendly color touch screen operator panel
- Automatic packaging film drive with tension control
- Automatic trim winder with tension control
- Package feed interval control with sensor and PLC

### Sealing:

- Smooth and linear weld line with center weld feature
- Adjustable cutting force and pressure accuracy
- PID controlled temperature settings on the touch panel
- Welding blades suitable for various packaging materials
- Under-seal bar product control and product protection

### Flexibility:

- Easy adjustment for different product sizes and capacities
- Various language options and adaptive touchscreen
- Memory Receipt property for prompt adjustments
- Perfect sealing blade design for varying thicknesses

### Optional:

- Ability to work without the need for compressed air
- External conveyor speed control from operator panel
- Sensor and programming for printed film use
- Ability to use single layer flat film by center-folding unit
- Stabilizing unstable products with the top pressure roller
- Linking Belt (6 bar compressed air is required)

### Quality:

- Worldwide brands on mechanical, electrical, pneumatics
- ISO 9001 quality and CE certificates
- Festo Pneumatics, Eaton, Omron, Siemens components
- 1 year warranty, 5 years spare parts supply warranty
- Spare parts stock and manufacturer support after sales



[www.packpark.com.tr](http://www.packpark.com.tr)

**INDUSTRIAL  
PACKAGING**

# HYBRID SERIES

## HIGH PRODUCT AUTO SHRINK WRAPPER

### SPECIFICATIONS

Minimum Package Width:  
Maximum Cycle:  
Maximum Speed:  
Sealer Opening:  
Cross Sealer Length:  
Working Height:

350mm (Optional 150mm)\*  
25 packs/min  
30 m/min  
400mm  
800mm  
860mm

### TECHNICAL DATA

Conveyor Belt Width:  
Maximum Film Width:  
Film Types:

600mm  
1000mm  
7-40 PO, PP "V" Knife  
40-80 PE, OPP "W" Knife  
Ø 270mm  
Mixed grey+ RAL7010 + RAL7015

Max. Roll Diameter:  
Color:

Compressed Air:  
Installed Power:  
Consumption  
(Max./Average):  
Dimensions (WxLxH):  
Palletized Size (WxLxH):  
Weight (Net / Gross):

No need\*\*  
400V, 3Phase, 50-60 Hz  
7kW / 5kW  
1650 x 3210 x 2110mm  
1855 x 3410 x 1850mm  
1300 kg / 1500 kg

\* Real working speed depends on the product dimensions and the film type.

\*\* Kissing Belt requires air. Air requirement: 6 Bar - 87psi, Air Consumption: 0,5liters / cycle

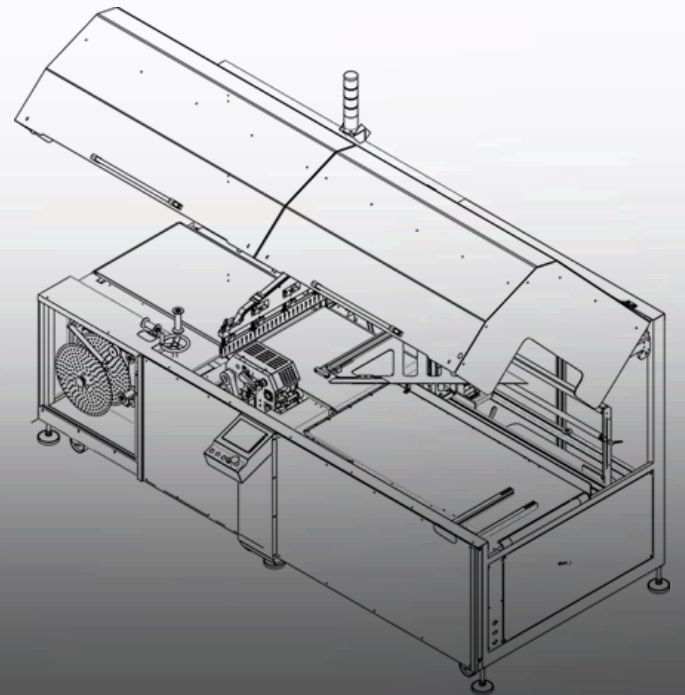
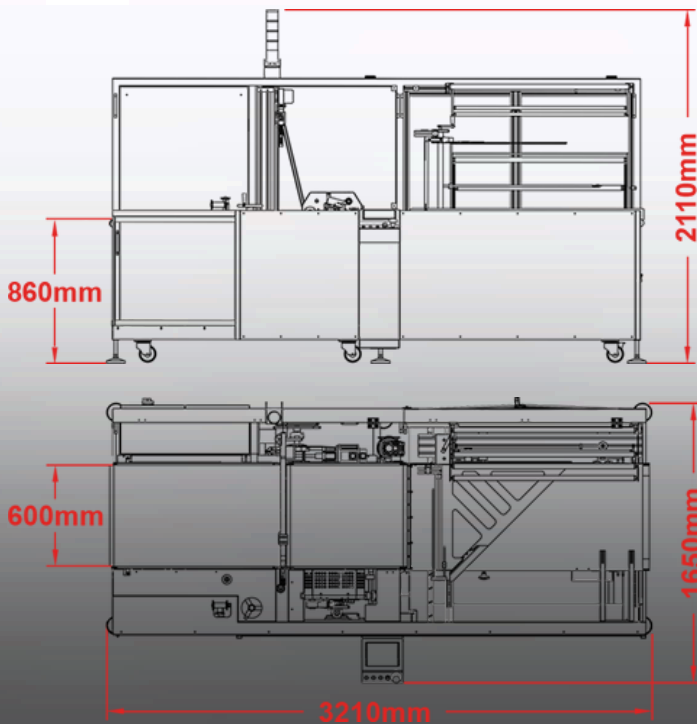

[www.packpark.com.tr](http://www.packpark.com.tr)

**INDUSTRIAL  
PACKAGING**

FOR MORE INNOVATIVE  
PACKAGING SOLUTIONS



 [info@packpark.com.tr](mailto:info@packpark.com.tr)

 +90 533 690 0555



Park Industrial Packaging Equipments Ltd.  
Esentepe, Kelebek Sk. No:2, Marmara Kule A Blok 203, 34870 Kartal/Istanbul - TURKIYE  
Tel. +90 216 353 5466 Mobile/WhatsApp: +90 533 690 0555  
[info@packpark.com.tr](mailto:info@packpark.com.tr) [www.packpark.com.tr](http://www.packpark.com.tr)

**INDUSTRIAL  
PACKAGING**