

ADVANCED PACKAGING
TECHNOLOGIES



LMC SERIES

SEMI AUTOMATIC L SEALER

GROW YOUR BUSINESS

www.packpark.com.tr



LMC SERIES

SEMI AUTOMATIC L SEALER



Advantages:

- Compact body design saves floor space
- Easy and safe use in accordance with OHS requirements
- Sealing wire temperature control with I-Sealing System®
- I-Sealing System® stabilizes the target wire temperature
- Motor-driven Sealing L-Bar (no compressed air required)
- Automatic sealing mode with time adjustment

Features:

- Easy to integrate with all types of heat tunnel directly
- Automatic product discharge with built-in belt conveyor
- Easy operation with digital control panel
- Adjustable feeding table according to product width
- Easily removable and replaceable film roll holding profile
- Easily transportable on wheels inside a facility

Sealing:

- In free mode, sealing bar is triggered by button
- Quiet operation with motor-driven sealing bar
- Sealing wire is positioned on fixed bottom frame for safety
- Sealing wire is embedded into heat-resistant fiber profile

Flexibility:

- Adjustable conveyor height for different product heights
- Conveyor running times according to product lengths
- Cutting wire power adjustment for the film thicknesses used
- Different language options can be selected via control panel

Optional:

- Automatic trim winder option is available upon request
- Pedal control option for hands-free operation
- Stainless steel versions are available
- On-site installation and training service options

Quality:

- CE and ISO 9001 quality standard with the relevant norms
- One year warranty on non-wearable parts
- Manufacturer's guarantee for spare part & after sales
- 1 set of wear parts is provided along with the machine LMC



www.packpark.com.tr

**INDUSTRIAL
PACKAGING**

LMC SERIES

SEMI AUTOMATIC L SEALER

SPECIFICATIONS

Sealer Bar Opening:
Maximum Capacity:
Maximum Product Height:
Maximum Roll Diameter:
Working Height:
Compressed Air Supply:
Film Types:
Color:

250mm
10 - 15 pack/min.*
150mm
Ø 250mm
860mm
No
POF: 7-37 micron / PVC: 15-25 micron
Light gray RAL7035

TECHNICAL DATA

Max. Packaging Sizes (WxLxH):
Working Principle:
L - Sealer Sizes:
Max. Film Width:
Installed Power (50-60Hz):
Consumption Max./ Average
Dimensions (AxBxC):
Palletized Size (AxBxC):
Weight (Net/Gross):

LMC 58X44-M

300 x 450 x 150mm
Motorized
580 x 440mm
550mm
400V, 10 A, Phase
2 kW / 1kW
910 x 1525 x 1180mm
1060 x 1675 x 1080mm
148 kg / 166 kg

LMC 80X65-M

450 x 650 x 150mm
Motorized
800 x 650mm
700mm
400V, 10 A, Phase
2 kW / 1kW
1145 x 2150 x 1300mm
1300 x 2300 x 1210mm
201 kg / 226 kg

*Real working speed depends on the product dimensions and the film type.

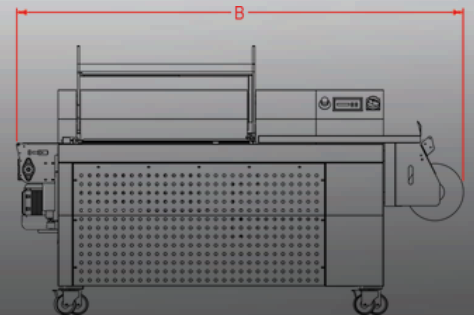
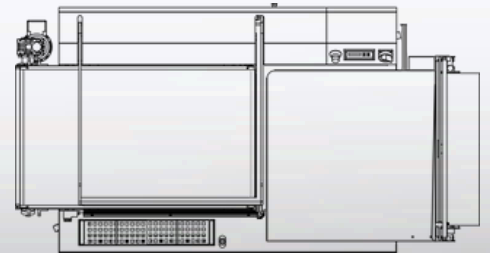
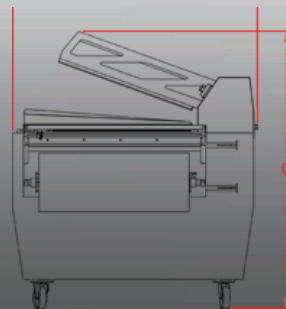
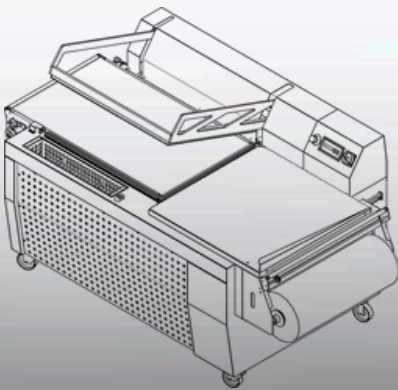

www.packpark.com.tr

**INDUSTRIAL
PACKAGING**

FOR MORE INNOVATIVE
PACKAGING SOLUTIONS



 info@packpark.com.tr

 +90 533 690 0555



Park Industrial Packaging Equipments Ltd.
Esentepe, Kelebek Sk. No:2, Marmara Kule A Blok 203, 34870 Kartal/İstanbul - TÜRKİYE
Tel. +90 216 353 5466 Mobile/WhatsApp: +90 533 690 0555
info@packpark.com.tr www.packpark.com.tr

**INDUSTRIAL
PACKAGING**